

Guide Rails 导轨



RideStar★★★★★

塞维拉Star(星级)导轨
Special Savera Guide



 **Savera**

Elevator System Solutions



RideStar★ ★ ★ ★ ★

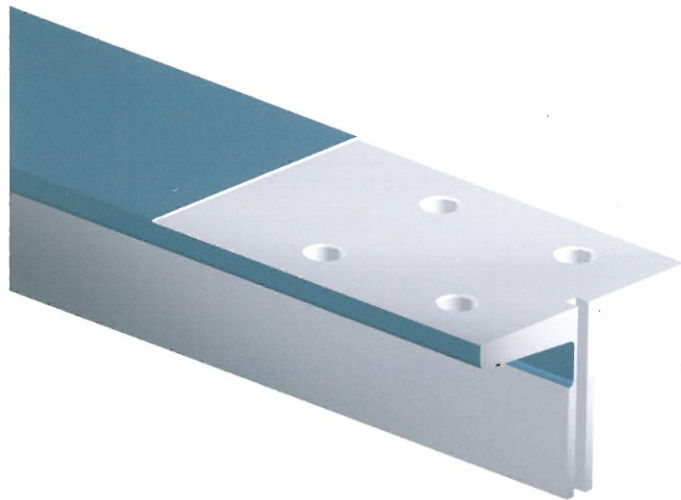

塞维拉Star(星级)导轨

塞维拉Star（星级）导轨丰富了高速电梯的高品质导轨产品线。

该导轨尤其推荐用于速度高于4米/秒的电梯。

在直线度和端部生产过程中使用了100%自动化控制，

我们的自动生产线能够保证导轨的精度，使其区别于市场上的其他产品。

Special SAVERA Guide

With this **Star Line**, Savera completes the range of **high quality guides** needed to fully service the **high-speed elevator** market. This line is especially recommended for lifts with speeds above 4 m/s.

With 100% automatic and on-line control in straightening and machining of the ends, Savera is able to guarantee the required tolerances for this guide line - **unique in the market.**

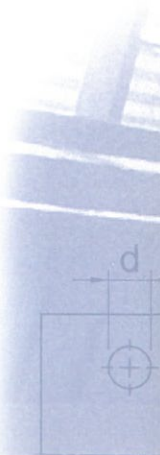

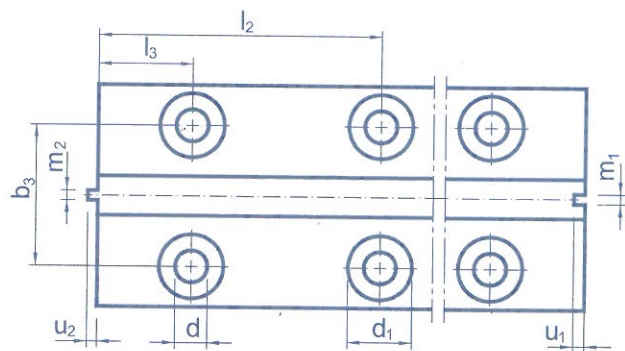
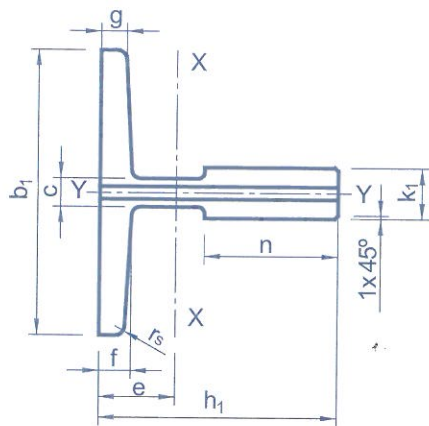

导轨型号 与尺寸和连接板及螺栓孔距 / Dimensions and distance between holes, fishplates and bolts

导轨型号与尺寸(mm.)
Dimensions(mm.)

	$b_1 \pm 1,50$	$h_1 \pm 0,75$	$h \pm 0,03$	l	$+3$ -0	$+0,05$ -0	$+3$ -0	c	$g \pm 0,75$	$f \pm 0,75$	r_s	m_1	$+0,02$ -0	$+0$ $-0,02$	$u_1 \pm 0,10$	$u_2 \pm 0,10$	直线度/Straightness	
																	f/5m max. mm	f/m max. mm
T125/B	125	82	81	156	16	42	10	9	12	4	6,4	6,38	7,14	6,35	0,5	0,2		
T127-2/B	127	89	88	156	16	51	10	12,7 [†]	15,9	5	6,4	6,38	7,14	6,35	0,5	0,2		
T140-1/B	140	108	107	193	19	51	12,7	12,7	15,9	5	6,4	6,38	7,14	6,35	0,5	0,2		
T140-2/B	140	102	101	193	28,6	51	17,5	14,5	17,5	5	6,4	6,38	7,14	6,35	0,5	0,2		
T140-3/B	140	127	126	193	31,75	57	19	17,5	25,4	5	6,4	6,38	7,14	6,35	0,5	0,2		

连接板及螺栓的孔距(mm.)

Distance between holes, fishplates and bolts(mm.)

	d	d_1	b_2	$b_3 \pm 0,20$	l_1	$+3$ -0	$l_2 \pm 0,20$	$l_3 \pm 0,20$	v	$+3$ -0	Tornillo Bolt	Arandela Washer
T125/B	17	33	130	79,4	305	114,3	38,1	28	M16x60	A-16		
T127-2/B	17	33	130	79,4	305	114,3	38,1	28	M16x60	A-16		
T140-1/B	21	40	140	92,1	380	152,4	31,8	38	M20x80	A-20		
T140-2/B	21	40	140	92,1	380	152,4	31,8	38	M20x80	A-20		
T140-3/B	21	40	140	92,1	380	152,4	31,8	48	M20x80	A-20		

技术参数

Technical Characteristics

	Sección Section cm 2	Peso Weight kg/m	e cm	I_{xx} cm 4	W_{xx} cm 3	i_{xx} cm	I_{yy} cm 4	W_{yy} cm 3	i_{yy} cm
T125/B	22,82	17,91	2,43	151	26,16	2,572	159,1	25,46	2,641
T127-2/B	28,72	22,55	2,478	201,7	31,17	2,64	229,9	36,2	2,829
T140-1/B	35,15	27,59	3,236	403,3	53,32	3,387	309,7	44,24	2,968
T140-2/B	43,21	33,92	3,484	456,7	68,01	3,251	358,2	51,18	2,879
T140-3/B	57,52	45,15	4,418	947,5	114,4	4,059	466,7	66,67	2,848



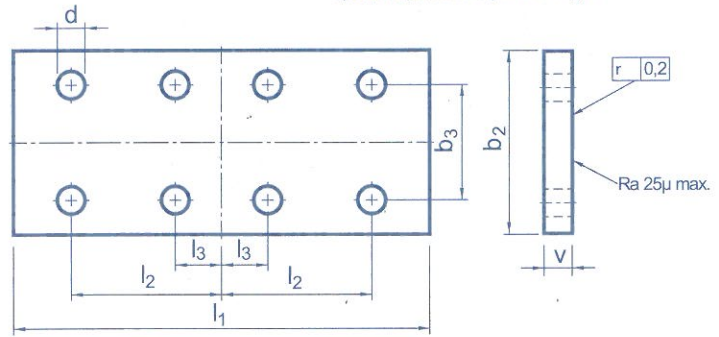
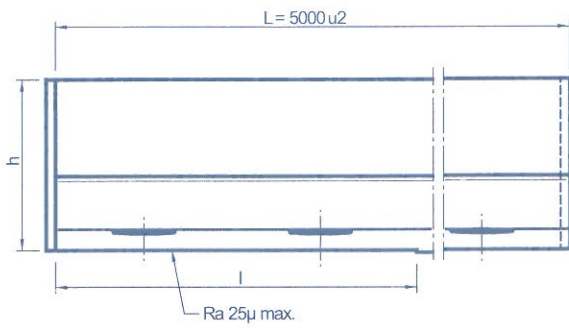

标准连接板
Standard fishplate.

特殊连接板请见目录
Special fishplates in Fishplates catalogue.

ISO 7465:2007

导轨主要参数 General Characteristics of the Guides

标准 Standards
ISO 7465
UNI 7465
ANSI A 17-1
BS 5655
DIN 15311
JIS
AFNOR NF P 82/251

机械性能 / Mechanical Characteristics

	抗拉强度 Breaking point N/mm ²	屈服点 Yield point N/mm ² min.	延伸率 Elongation %
导向面 Blade ≤ 16mm	410 -520	275	≥ 22
导向面 Blade > 16mm	410 -520	265	≥ 22

化学成分 Chemical Composition

C% Max.	Mn% Max.	P% Max.	S% Max.	Si% Max.
0,21	1,5	0,045	0,045	0,4

防锈保护 Anti-rust Protection (*)

型号 Type	厚度 Thickness	室外存放月 Months outdoors	室内存放月 Months indoors
Tectyl 511 M (油/oil)	2 - 10 µ	•	1 - 3
Tectyl 502 C (蜡/wax)	20 - 30 µ	0 - 1	4 - 8
Tectyl 506 WD (cera/wax)	标准 Standard	20 - 30 µ	1 - 3
	特殊 Special	40 - 50 µ	3 - 6



(*)数据会根据环境的湿度和清洁程度发生变化
(*)Orientative data with change according to environment humidity and salinity.

重量(千克)和包装 / Weights (kg) and Packing

编号 Code	单根重量 Weight/ guide	包装后重量 Weight/packed guide	包装后含 连接件重量 Weight/packed guide and accessories	每捆数量 No. of guides per bundle	20尺集装箱可装数量 No. of guides per 20ft container	
					含连接件 With accessories	不含连接件 Without accessories
T125/B	89,55	90,55	97,83	10	220	230
T127-2/B	112,75	113,75	121,03	10	170	190
T140-1/B	137,95	139,95	153,13	5	135	150
T140-2/B	169,6	171,6	184,78	5	115	125
T140-3/B	225,75	227,75	243,57	5	85	90

防锈油去除 / Anti-rust Protection Removal

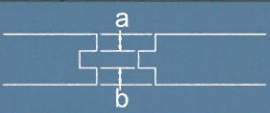
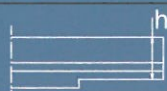
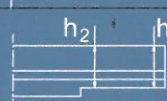
产品 Product	溶解度 Solubility in water (% weight)
TFR溶剂 Tectyl Solvent TFR	50

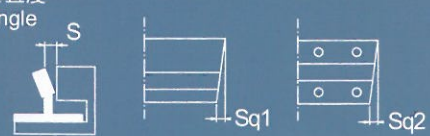
	参数 Parameter	机加工 Machined 公差 / Tolerance
直线度 Straightening		见导轨尺寸参数表 Data indicated in "Dimensions" table
对称度 Centring		a - b ±0,03 mm
导轨高度 Guide height		h ±0,03 mm
平行度 Parallelism base		h - h ₂ ±0,05 mm
(榫 - 槽) (key-keyway) 最大间隙 Maximum clearance		E max. 0,06 mm
粗糙度 Roughness		Ra Long. 1,6 μ max.
		Ra Transv. 0,8 - 3,2 μ
扭曲度 Twist		R max 1 mm / 5 m
垂直度 Angle		s max. ±0,05 mm
		sq1 ±0,10 mm
		sq2 ±0,05 mm

特点 / Characteristics

交货 Supply	保护 Protection	长度 Length	连接板 Fishplates
包装 • 带螺栓的钢带 • PE膜 • 4档垫木 • 两端带保护套 • 中间加夹子 可选 全身覆盖	• 蓝色油漆 • Tectyl 506 WD 防锈油 可选 -Tectyl 502 C -Tectyl 511 M	5 m.	标准 连接板
Packing • Steel sheet with bolts • P.E. Foam • 4 wooden blocks at the bottom • Caps • Spacers Optional -Cover protection	• Blue paint • Tectyl 506 WD Options -Tectyl 502 C -Tectyl 511 M	5 m.	Standard fishplate

RideStar★★★★★

塞维拉Star(星级)导轨 Special Savera Guide

塞维拉中国
Savera China
Tel: +86 21 51748778 Fax: +86 21 51748712
Email: shanghai@saveragroup.sh.cn
中国上海市浦东陆家嘴环路166号未来资产大厦20楼
20/F Mirae Asset Tower, 166 Lujiazui Ring Road,
Pudong Shanghai, P.R. China
Postcode邮编: 200120

北京首钢塞维拉电梯导轨有限公司
Beijing Shougang Savera Elevator Guide Rail Co., Ltd.
Tel: +86 10 60259670 Fax: +86 10 60259347
Email: sal.dept@saveragroup.bj.cn
北京大兴黄村
Huangcun, Daxing, Beijing, P.R. China
Postcode邮编: 102600

苏州塞维拉上吴电梯轨道系统有限公司
Suzhou Savera Shangwu Elevator Riding System Co., Ltd.
Tel: +86 512 63244618 Fax: +86 512 63245658
Email: shangwu_sales@saveragroup.js.cn
中国苏州吴江北库镇开发区内
West Beishe, Wujiang, Jiangsu, P.R. China
Postcode邮编: 215214

天津塞维拉电梯轨道系统有限公司
Tianjin Savera Elevator Riding System Co., Ltd.
Tel: +86 22 26999008 Fax: +86 22 86990080
Email: tianjin_sales@saveragroup.tj.cn
中国天津新技术产业园区北辰科技工业园
津围公路东侧景远路2号
2 Jingyuan Road, East Jinwei Road,
Beichen Science and Technology Park,
Tianjin Hi-tech Industrial Park, Tianjin, P.R. China
Postcode邮编: 300400

广州塞维拉电梯轨道系统有限公司
Guangzhou Savera Elevator Riding System Co., Ltd.
Tel: +86 20 39965678 Fax: +86 20 39965663
Email: guangzhou_sales@saveragroup.gd.cn
中国广州市番禺区石楼镇国贸大道南636号之二
No. 2 South Guomao Avenue 636, Shilou Town,
Panyu District, Guangzhou, P.R. China
Postcode邮编: 511447

浙江海通钢业有限公司
Zhejiang Hitone Steel Product Co., Ltd.
Tel: +86 573 84191888 Fax: +86 573 84191666
Email: haitonggangye@yahoo.com.cn
浙江省嘉善市魏塘镇伍子塘路18号
18 Wuzitang Road, Weitang Town, Jiashan city,
Zhejiang, P.R.China
Postcode邮编: 314100



Elevator System Solutions